

### Features

**4100U Series MINIPLEX transponders allow remotely located initiating and notification functions:**

- Transponder operation is available as standard or with local mode operation
- Communications with the host fire alarm control panel use the Remote Unit Interface (RUI) format

#### Initiating functions include:

- Conventional initiating device circuit (IDC) support
- Addressable device support including TrueAlarm® analog sensor compatibility\*\*

#### Notification functions include:

- Conventional DC notification appliance circuits
- Emergency voice/alarm communications
- TrueAlert® addressable strobe and horn notification

#### Local mode operation provides:

- Default local initiating and notification operation in the event of a communications loss with the host control panel
- Enabling of an optional Local Mode Controller with a local alarm sounder, LED status indicators, and keyswitch enabled control switches
- Support for IDNet™ addressable devices, conventional and TrueAlert addressable notification appliances, and default output tones from local amplifiers\*\*

#### Optional modules include:

- Digital or Analog audio riser modules for connection to system audio signals
- Digital or analog input audio amplifiers with integral on-board NACs
- Power supplies with or without battery chargers
- City Connect modules and RS-232 ports for printers or maintenance terminals
- Alarm relays, auxiliary relays, additional IDC modules, and NAC expansion modules

**Cabinets are equipped with solid doors (beige or red) and in two or three bay sizes**

#### Listed to:

- UL Std. 864, Fire Detection and Control (UOJZ), and Smoke Control Service (UUKL)
- UL Std. 2017, Process Management Equipment (QVAX)
- UL Std. 1076, Proprietary Alarm Units-Burglar (APOU)
- UL Std. 1730, Smoke Detector Monitor (UULH)
- ULC Std. S527-99

\* See pages 4 and 5 for product that is listed as UL or ULC. This product has been approved by the California State Fire Marshal (CSFM) pursuant to Section 13144.1 of the California Health and Safety Code. See CSFM Listing 7165-0026:251 (non-high rise) and 7170-0026:250 (high rise) for allowable values and/or conditions concerning material presented in this document. It is subject to re-examination, revision, and possible cancellation. Accepted for use – City of New York Department of Buildings – MEA35-93E. Additional listings may be applicable; contact your local Simplex product supplier for the latest status. Listings and approvals under Simplex Time Recorder Co. are the property of Tyco Safety Products Westminster.

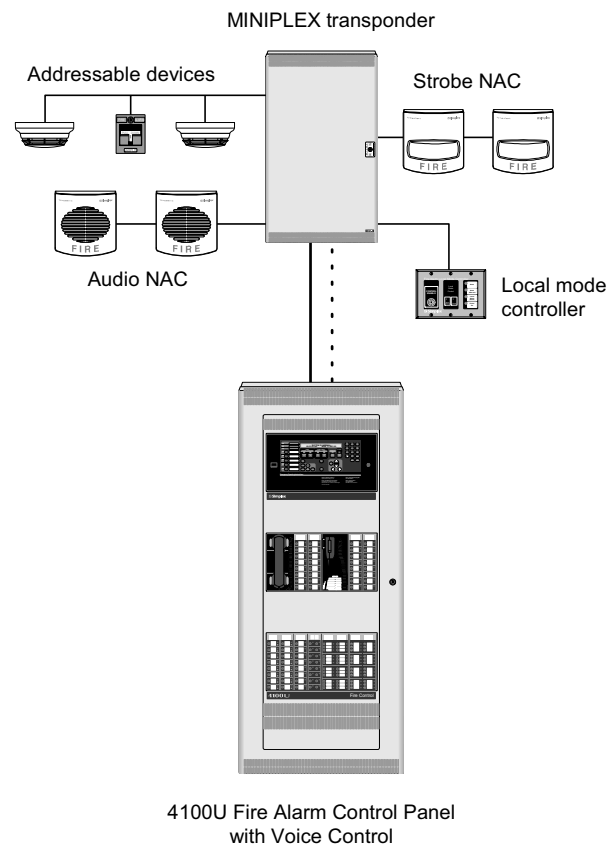

Typical 4100U MINIPLEX System One-Line Drawing

### Introduction

**4100U MINIPLEX transponders** connect to a host 4100U Fire Alarm Control Panel using Simplex® remote unit interface (RUI) communications. At the transponder, RUI communications are received by the transponder interface module and translated into the same internal communications format that is used in the host control panel.

**Remotely located modules.** With RUI communications, the transponder can remotely provide the same initiating and notification functions that occur at the host control panel without requiring multiple long distance wiring runs. Connections to the host panel are low current communications and audio wiring with distances up to 2500 ft (762 m).

**Software Revisions.** Some of the features detailed and products listed in this document require 4100U System Software Revision 11.08 or higher. For pre-11.08 system expansion options, hardware updates may be required. Contact your local Simplex® product supplier for details.

\*\* Simplex fire alarm technology is protected by the following U.S. Patent Numbers: TrueAlarm analog smoke detection: 5,155,468; 5,173,683 and 5,543,777. IDNet and MAPNET II addressable communications; 4,796,025. TrueAlert addressable notification; 6,313,744 and 6,426,697. SmartSync horn/strobe control; 6,281,789. Flex-35 and Flex-50 amplifier operation; 6,452,491.

## Introduction (Continued)

Please refer to document S4100-0031 and the other documents listed on page 3 for additional information concerning the extensive initiating and notification features of the 4100U fire alarm control panels.

## Module Bay Description

**Transponder model 4100-9600** includes a bay assembly, a power distribution interface module (PDI), a Basic Transponder Interface Module, and an interconnect harness. Communications with the host fire alarm control panel are via a Remote Unit Interface (RUI) connection that allows for up to 2500 ft (762 m) distance. RUI can communicate with up to a total of 31 remote devices and can be either Style 4 or Style 7 communications.

**Transponder model 4100-9601** substitutes a Local Mode Transponder Module for the Basic Transponder Module.

**Optional Expansion Bays** each include a PDI and accept a variety of optional modules (refer to list starting on page 4).

**The Battery Compartment** (bottom) accepts two batteries, up to 50 Ah, that can be mounted within the cabinet. Battery mounting does not interfere with available module space. A power supply with battery charger is required for each battery set.

## Packaging Availability

- Modules are power-limited (except as noted, such as relay modules)
- Enclosure are available for either two or three bay sizes or for cabinet rack mounting
- Boxes and solid doors are available in beige or red (ordered separately)
- Up to eight close-nipped cabinets can be connected at one transponder location (close-nipped is mounted within 20 ft (6 m) and with interconnecting wiring enclosed in conduit)
- Refer to document S4100-0037 for enclosure details

## Local Mode Control Operation

**Default Stand-Alone Operation.** In the event of a communications loss with the host fire alarm control panel, model 4100-9601 MINIPLEX Local Mode Transponders provide fire alarm response default operation for its connected devices and appliances per the following.

**Input Operation.** During local mode operation, TrueAlarm initiating devices connected to the transponder will cause an alarm at their least sensitive alarm threshold.

- Photoelectric sensors will alarm at 3.7%/ft smoke obscuration
- Ionization sensors will alarm at 1.3%/ft obscuration
- Heat sensors will alarm at a fixed temperature of 135° F (57° C)
- TrueAlarm device LEDs will be activated to indicate a device in alarm

## Local Mode Control Operation (Continued)

**Notification Operation.** Fire alarm conditions reported against a fire alarm point type within a transponder in local mode will cause all notification appliance circuits in that transponder to:

- Sound a general alarm temporal pattern horn tone
- Activate visible notification appliance circuits

**Local Mode Module Support.** Local mode operation provides support for the following 4100U modules:

- System Power Supplies (SPS), Expansion Power Supplies (XPS), and Remote Power Supplies (RPS), including on-board notification appliance circuits (NACs) and expansion signal modules, operated at a temporal pattern,
- TrueAlert Power Supplies (TPS) including the on-board signaling line circuits (SLCs)
- IDNet addressable device circuits, including those on-board the SPS, IDNet expansion modules, and the quad isolator when used for IDNet communications
- 4100U amplifiers will provide their on-board horn tones (500 Hz) at a temporal pattern through their on-board amplifier NACs

**Local Mode Operation Module Exclusion.** Modules not listed above but that are listed as compatible with MINIPLEX transponders per this document, do not interfere with local mode operation but **are not supported** during local mode operation.

## Local Mode Controller

**Operation.** During local mode operation, an optional Local Mode Controller will indicate status (see illustration below) and can be enabled using a keyswitch to perform local alarm silence or reset. If alarms occurring during local mode are reset using a Local Mode Controller, upon restoration of communications, **those alarms will not be sent to the master controller.** If alarms are still present upon restoration of communications, then the alarm condition will be reported and host fire alarm control panel programmed alarm functions will occur. When communications are re-established, the local mode transponder restores automatically.

**Mounting.** Local Mode Controllers are mounted on three-gang plates, are available in beige or red, and for either flush or semi-flush mounting. (See page 7 for details).

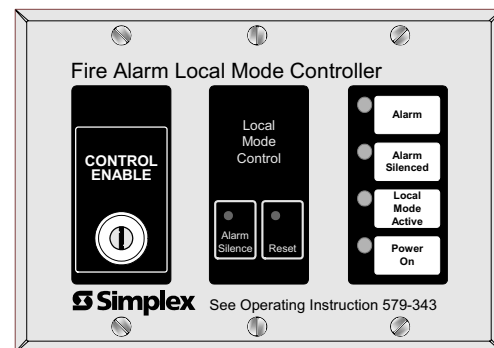

Local Mode Controller Module

## Typical Multi-Floor MINIPLEX Audio System

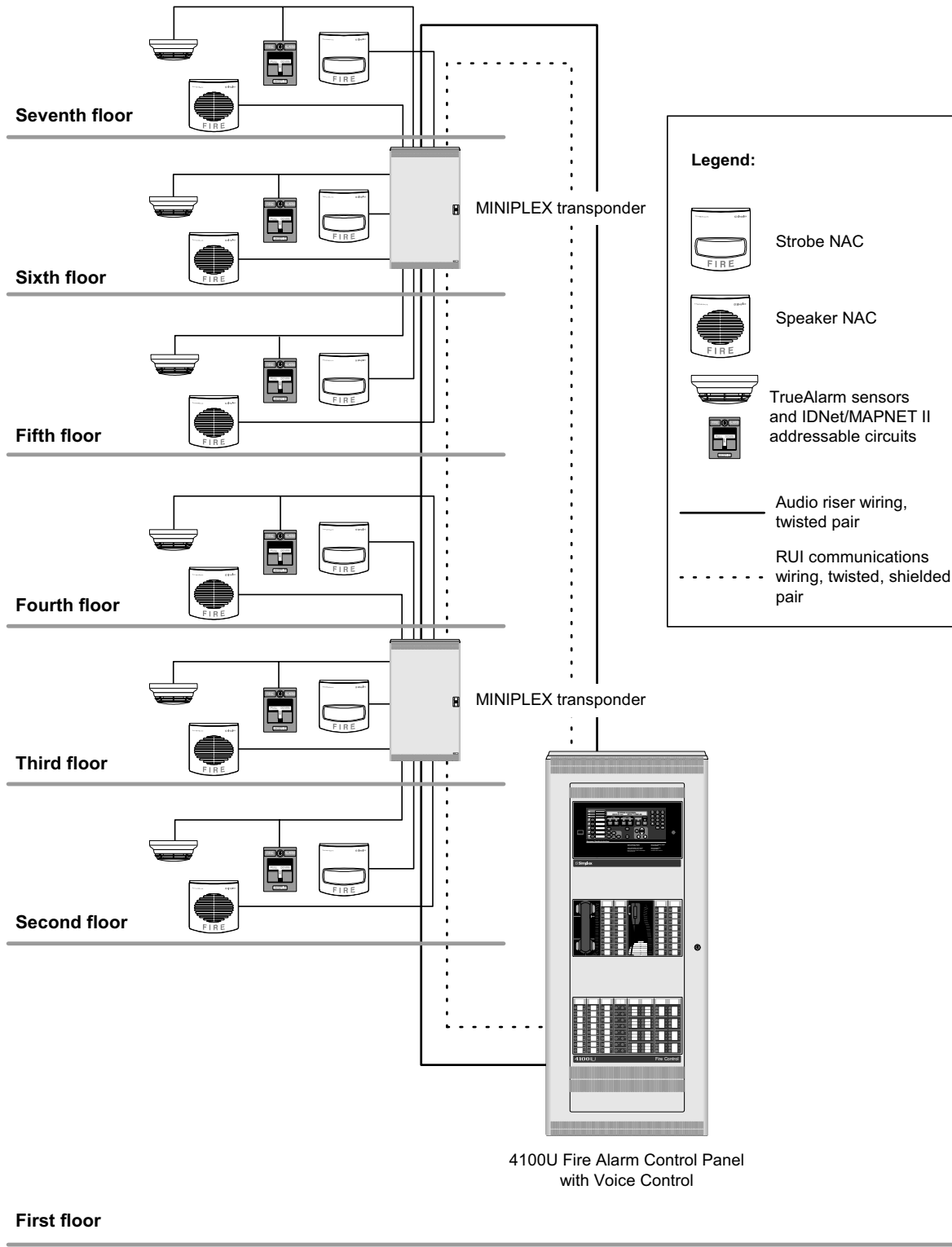

## Additional 4100U Data Sheet Reference

Subject	Data Sheet	Subject	Data Sheet
Enclosures	S4100-0037	Basic Panel Modules and Accessories	S4100-0031
LED/Switch Modules	S4100-0032	Network Display Unit (NDU)	S4100-0036
4100U Audio/Phone Modules	S4100-0034	Remote Annunciators	S4100-0038
TrueAlert Addressable Products	S4009-0003	Remote Battery Charger	S4081-0002

## MINIPLEX Transponder Product Selection

### Transponder Type

Model	Description	Supv.	Alarm
4100-9600	Basic Transponder, includes bay equipment with power distribution interface, and 4100-0620 Basic Transponder Interface Module mounted in Block A	87 mA	87 mA
4100-9601	Local Mode Transponder, includes bay equipment with power distribution interface, and 4100-0625 Local Mode Transponder Interface Module mounted in Block A	normal	87 mA
		in local mode	112 mA

### Local Mode Controller Selection

Model	Description	Supv.	Alarm
4601-9108	Flush mount	normal	10 mA
4601-9109	Surface mount		
4601-9110	Flush mount	in local mode	20 mA
4601-9111	Surface mount		

### Communication Modules

Model	Description	Size	Supv.	Alarm		
4100-6031	<b>Select one per SPS</b>	Mounts on SPS or RPS	20 mA	36 mA		
4100-6032					City Circuit, with disconnect switches	For use with SPS only, not RPS
4100-6033					City Circuit, without disconnect switches	
4100-6038	Dual RS-232 Interface	1 Slot	132 mA	132 mA		
4100-6045	Decoder Module	3 Slots	85 mA	163 mA		
4100-6048	VESDA® Aspiration System Interface	1 Slot	132 mA	132 mA		
4100-9816	Master Clock Interface Module with one standard RS-232 port (see S4100-0033)	1 Slot	132 mA	132 mA		

### Expansion, System, Remote, and TrueAlert Power Supplies and Accessories

Model	Voltage/Listing	Description	Size	Supv.	Alarm
4100-5101	120 VAC	<b>Expansion Power Supply (XPS)</b> ; 9 A output, 3 built-in Class A/B NACs; Canadian models have low battery cutout*	2 Blocks	50 mA	50 mA
4100-5103	120 VAC, Canadian				
4100-5102	220-240 VAC				
4100-5115	NAC Expansion Module, 3 NACs, Class A/B, <b>mounts on XPS only</b>		N.A.	25 mA	25 mA
4100-5111	120 VAC	<b>System Power Supply (SPS)</b> ; 9 A power supply/charger with 250 point IDNet channel, 3 Class A/B NACs, and expansion slot for City Circuit or Alarm Relay option; Canadian model has low battery cutout*	4 Blocks	175 mA	225 mA
4100-5112	120 VAC, Canadian				
4100-5113	220-240 VAC				
4100-5125	120 VAC	<b>Remote Power Supply (RPS)</b> ; 9 A power supply/charger similar to SPS except no IDNet channel or City Circuits, will accept one 4100-6033; Canadian model has low battery cutout*	4 Blocks	150 mA	185 mA
4100-5126	120 VAC, Canadian				
4100-5127	220-240 VAC				
4100-5120	120 VAC	<b>TrueAlert Power Supply (TPS)</b> ; 3 built-in Class B addressable Signaling Line Circuits (SLCs) rated 3 A each, built-in battery charger, with 2 A auxiliary power output tap; Canadian model has low battery cutout	4 Blocks	88 mA	100 mA
4100-5121	120 VAC, Canadian				
4100-5122	220-240 VAC				
4100-5124	TrueAlert SLC Class A Adapter for all 3 SLCs, <b>mounts on TPS only</b>		N.A.	7 mA	7 mA
4100-5152	12 VDC Power Option, 2 A maximum		1 Block	1.5 A maximum	
4100-0636	Box Interconnection Harness Kit (non-audio); <b>order one for each close-nipped cabinet</b>				

### Miscellaneous Options and Accessories

Model	Description
4100-1290	24 Point I/O Module for external connections, select each point as either a switch input (momentary or maintained) or an output (for lamp/LED/relay); requires 1 Slot (refer to data sheet S4100-0032 for additional information)
4100-0632	Terminal Block Utility Module; provides 2, 16 position terminal blocks mounted on 4" x 5" single block size, capable of up to 12 AWG wire (3.31 mm <sup>2</sup> )
4100-0633	Door Tamper Switch, connects into Transponder Interface Module, one per cabinet assembly if required
4100-0634	Power Distribution Module (PDM) select per system voltage; <b>one required per box</b>
4100-0635	
4100-9837	Green LED Power-on Indicator Kit, <b>required for ULC listing of MINIPLEX transponder</b>
2081-9031	Mounts using knockout provided in solid door
2081-9031	Series resistor for WSO, IDCs (N.O. water flow and tamper on same circuit, wires after water flow and before tamper) 470 Ω, 1 W, encapsulated, two 18 AWG leads (0.82 mm <sup>2</sup> ), 2-1/2" L x 1-3/8" W x 1" H (64 mm x 35 mm x 25 mm)

\* Power supply NACs can provide synchronized strobe or SmartSync, two-wire operation.

Continued on next page

## MINIPLEX Transponder Product Selection (Continued)

### Audio Riser Modules

Model	Description	Size	Supv.	Alarm
4100-0621	Dual Channel <i>Analog</i> Audio Riser Module; accepts one or two separate audio signals from host control panel; mounts in Block B, is controlled by Transponder Interface Module	1 Block	0 mA	0 mA
4100-0622	3-8 Channel <i>Digital</i> Audio Riser Module; similar to analog module, except receives and decodes a digital input signal with up to eight audio channels; with Non-Alarm Audio input	1 Block	50 mA	50 mA

### Analog Emergency Voice/Alarm Communications Equipment, Constant Supervision Compatible\*

Model	Description	Details
4100-1361	25 VRMS output	Includes three on-board Class B audio NACs; power is supplied from an XPS, RPS, or SPS
4100-1362	70.07 VRMS output	
4100-1312	25 VRMS output	Includes three on-board Class B audio NACs; power is supplied from an XPS, RPS, or SPS
4100-1313	70.7 VRMS output	

### 100 W Analog Amplifiers with Power Supply, Constant Supervision Compatible

Model/Output Voltage		Power Supply Input/Listing		Description	Details
25 VRMS	70.7 VRMS				
4100-1314	4100-1315	120 VAC, 60 Hz	UL	Primary 100 W Amplifier	Includes six, Class B audio NACs; NAC rating = 50 W or 100 speakers maximum; 2 A @ 25 VRMS; 1.4 A @ 70.7 VRMS
4100-1316	4100-1317	120 VAC, 60 Hz	ULC		
4100-1318	4100-1319	220/230/240 VAC, 50/60 Hz	UL		
4100-1320	4100-1321	120 VAC, 60 Hz	UL	Backup 100 W Amplifier	Uses the six Class B NACs of primary amplifier
4100-1322	4100-1323	120 VAC, 60 Hz	ULC		
4100-1324	4100-1325	220/230/240 VAC, 50/60 Hz	UL		

### Digital Emergency Voice/Alarm Communications Equipment\*

Model	Description	Details
4100-1363	25 VRMS output	Includes three on-board Class B audio NACs; power is supplied from an XPS, RPS, or SPS
4100-1364	70.07 VRMS output	
4100-1326	25 VRMS output	Includes three on-board Class B audio NACs; power is supplied from an XPS, RPS, or SPS
4100-1327	70.7 VRMS output	

### 100 W Digital Amplifiers with Power Supply, Constant Supervision Compatible

Model/Output Voltage		Power Supply Input/Listing		Description	Details
25 VRMS	70.7 VRMS				
4100-1328	4100-1329	120 VAC, 60 Hz	UL	Primary 100 W Amplifier	Includes six, Class B audio NACs; NAC rating = 50 W or 100 speakers maximum; 2 A @ 25 VRMS; 1.4 A @ 70.7 VRMS
4100-1330	4100-1331	120 VAC, 60 Hz	ULC		
4100-1332	4100-1333	220/230/240 VAC, 50/60 Hz	UL		
4100-1334	4100-1335	120 VAC, 60 Hz	UL	Backup 100 W Amplifier	Uses the six Class B NACs of primary amplifier
4100-1336	4100-1337	120 VAC, 60 Hz	ULC		
4100-1338	4100-1339	220/230/240 VAC, 50/60 Hz	UL		

### Options for use with either Analog or Digital Amplifiers

Model	Description	Details and Mounting Reference
4100-1245	Flex-35/50 Expansion NAC Module; adds three Class B audio NACs	Mounts on Flex-35/50 assembly; NAC ratings = 1.5 A, 35/50 W, or 100 speakers maximum; <i>Supv</i> = 0.6 mA, <i>Alarm</i> = 60 mA
4100-1246	Flex-35/50 Class A Adapter Module; converts three on-board NACS to Class A operation	
4100-1248	100 W Amplifier Expansion NAC Module; NAC ratings = 1.5 A, 50 W, or 100 speakers max.	Provides six additional Class B audio NACs, mounts on 100 W amplifier assembly; <i>Supv</i> = 1.2 mA, <i>Alarm</i> = 120 mA
4100-1249	100 W Class A Adapter Module; NAC ratings = 2 A, 50 W, or 100 speakers max.	
4100-1259	25 VRMS Output; NAC rating = 2 A, 50 W, or 100 speakers max.	Converts three Class B audio NACS to Class A or Class B Constant Supervision NACs; mounts on Flex-35/50 or 100 W amplifier assembly; use two for the six NACs on 100 W amplifiers;
4100-1260	70.7 VRMS Output; NAC rating = 0.707 A, 50 W, or 100 speakers max.	

### Firefighters Telephone Options

Model	Description	Size	Supv.	In Use
4100-1272	Expansion Telephone Control Module with three Class B telephone NACS; required when telephone circuits are mounted in transponder;	1 Block	75 mA	329 mA max.
4100-1273	Telephone Class A Adapter Module; mounts on 4100-1272; no additional current required			

\* Refer to document S4100-0034 for additional audio information.

Continued on next page

## MINIPLEX Transponder Product Selection (Continued)

### Audio Expansion Signal Module and Options

Model	Description	Details and Mounting Reference	
4100-5116	Expansion Signal Module; three, 1.5 A Class B NACs for Audio applications; up to five maximum per amplifier; NAC rating = 1.5 A, 50 W, or 100 speakers maximum	Converts one NAC input to three NAC outputs; selects between two inputs; for Flex-35/50 amplifiers only, two input NACs are required; Single Block module mounts in expansion bay; <i>Supv = 18 mA; Alarm with 100 W amplifiers = 52 mA; Alarm with Flex-35/50 amplifiers = 80 mA</i>	
4100-1266	Expansion Signal Module NAC Expander; NAC rating = 1.5 A, 50 W, or 100 speakers max.	Expands module capacity to six, Class B NACs; <i>Supv = 0.6 mA; Alarm = 60 mA</i>	These modules mount on the 4100-5116; select one max. per 4100-5116 as required
4100-1267	Expansion Signal Module Class A Adapter; NAC rating = 1.5 A, 50 W, or 100 speakers max.	Converts 3 Class B, NACs to Class A; <i>Supv = 0.6 mA; Alarm = 30 mA</i>	
4100-1268	Expansion Signal Module Constant Supervision Adapter; Converts 3 Class B NACs to Constant Supervision Class B or Class A NACs; for 25 VRMS or 70.7 VRMS audio	NAC rating = 1.4 A, 50 W, or 100 speakers max.; Current vs operating voltage: <i>25 VRMS Supv = 10 mA; 25 VRMS Alarm = 35 mA; 70.7 VRMS Supv = 38 mA; 70.7 VRMS Alarm = 60 mA</i>	

### General Audio Options

Model	Description
4081-9018	End-of-line resistor harness for 70.7 VRMS NACs; 10 k $\Omega$ , 1 W
4100-2320	Audio Bay-to-Bay Interconnection Harness Kit; <b>order one for each audio bay addition</b>
4100-0637	Audio Box Interconnection Harness Kit; <b>order one for each close-nipped audio cabinet</b>

### Initiating Device Circuits (IDCs)

Model	Description	Size	Supv.	Alarm
4100-5005	Eight zones, Class B	1 Slot	75 mA	195 mA
4100-5015	Eight zones, Class A	1 Slot	75 mA	195 mA

### Addressable Interface Modules

Model	Description	Size	Supv.	Alarm	
4100-3101	IDNet Module, 250 point capacity	With 250 IDNet devices, add	–	200 mA	250 mA
4100-3104	IDNet Module, 127 point capacity	With 127 IDNet devices, add	–	102 mA	127 mA
4100-3105	IDNet Module, 64 point capacity	With 64 IDNet devices, add	–	51 mA	64 mA

IDNet Modules, Specifications for each capacity; Module size = 1 Block		Size	Supv.	Alarm
Module without devices		–	75 mA	115 mA
Loading per IDNet device		–	0.8 mA	1 mA

Model	Description	Size	Supv.	Alarm	
4100-3102	MAPNET II <sup>®</sup> Module, 127 point capacity, add devices separately; Module size = 2 Slots; Loading per MAPNET II device = 1.7 mA	Module without devices	–	270 mA	290 mA
		Fully loaded module, total	–	470 mA	490 mA
4100-3103	Isolator Module for MAPNET II or IDNet communications; converts one SLC into four isolated Class A or Class B outputs; up to two Modules can be connected to one SLC	1 Slot	50 mA	50 mA	

### Relay Modules; Nonpower-Limited

Model	Description	Resistive Ratings		Inductive Ratings		Size	Supv.	Alarm
4100-3202	4 DPDT w/feedback	10 A	250 VAC	10 A	250 VAC	2 Slots	15 mA	175 mA
4100-3204	4 DPDT w/feedback	2 A	30 VDC/VAC	1/2 A	30 VDC/120 VAC	1 Block	18 mA	70 mA
4100-3206	8 SPDT	3 A	30 VDC/120 VAC	1-1/2 A	30 VDC/120 VAC	1 Block	16 mA	200 mA

### Current Calculation Notes:

- For total supervisory current, add panel module currents to base system value **and** add all external loads panel-powered loads.
- For total alarm current, add panel module currents to base system alarm current **and** add all panel NAC loads **and** all external loads powered from panel power supplies.

## General Specifications

<b>Input Power</b> [System (SPS); Expansion (XPS); Remote (RPS); TrueAlert Power Supplies (TPS); and 100 W amplifiers]	120 VAC Models	3.5 A maximum @ 102 to 132 VAC, 60 Hz	
	220-240 VAC Models	1.75 A maximum @ 204 to 264 VAC, 50/60 Hz; separate taps for 220/230/240 VAC	
<b>Power Supply Output Ratings</b> (System, Expansion, and Remote Power Supplies)	Total Power Supply Output Rating	9 A total @ nominal 28 VDC, <b>including module currents and auxiliary power outputs</b>	Output switches to battery backup during mains AC failure or brownout conditions
	Auxiliary Power Tap	2 A maximum @ nominal 28 VDC	
	NACs Programmed for Auxiliary Power	2 A maximum per NAC, 5 A maximum @ nominal 28 VDC	
<b>Battery Charger</b> (System and Remote Power Supply)	Battery capacity range	6.2 Ah to 50 Ah; selectable via programming for batteries below 18 Ah; the SPS is UL listed for up to 110 Ah battery charging for remotely located batteries	
	Charger characteristics and performance	Temperature compensated, dual rate, recharges depleted batteries within 48 hours per UL Standard 864, to 70% capacity in 12 hours per ULC Standard S527	
<b>Environmental</b>	Operating Temp. Range	32° to 120°F (0° to 49° C)	
	Operating Humidity Range	Up to 93% RH, non-condensing @ 90° F (32° C) maximum	

## Local Mode Controller Detail

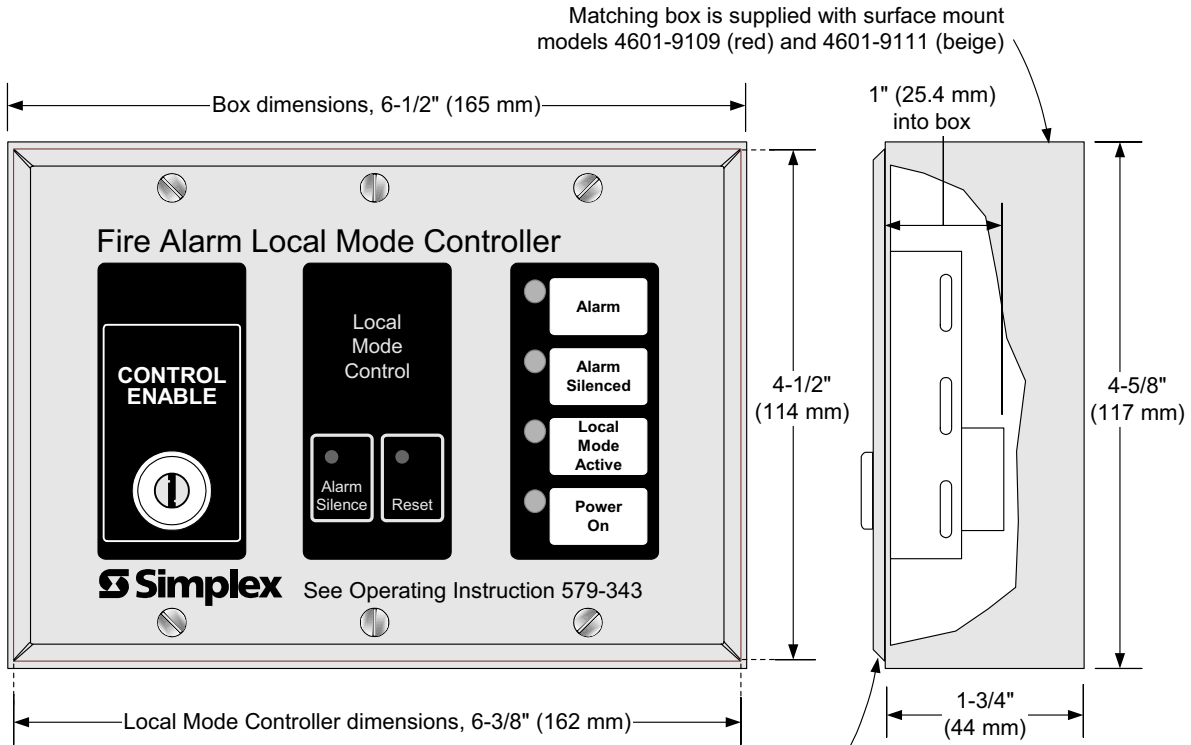

For semi-flush mounting, use a 1-1/2" deep (38 mm) 3-gang box

## Expansion Bay Module Loading Reference

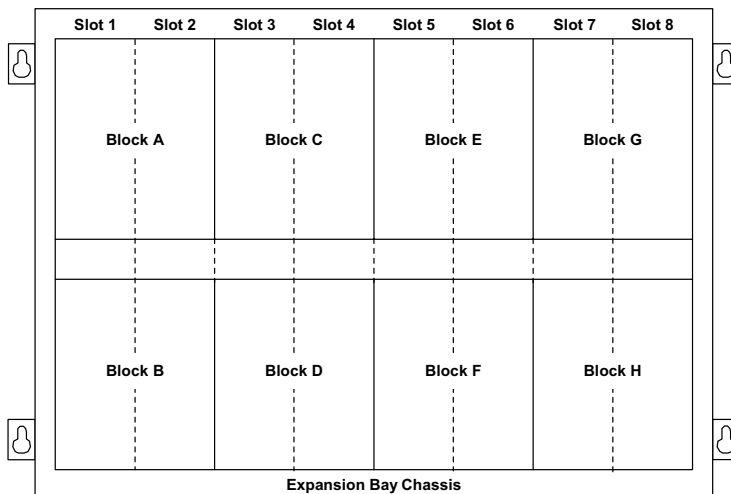

**Size Definitions:** Block = 4" W x 5" H (102 mm x 127 mm) card area

Slot = 2" W x 8" H (51 mm x 203 mm) motherboard with daughter card

Description	Mounting	
Transponder Interface Modules	Block A	
Audio Riser Modules	Block B	
Terminal Block Module	1 Block	
IDNet Modules	1 Block	
4, 2 A Relays	<b>NON Power-limited</b>	
4, 10 A Relays		1 Block
8, 3 A Relays		4", 2 Slots
VESDA Interface	1 Block	
Class B IDC	2", 1 Slot	
Class A IDC	2", 1 Slot	
MAPNET II Module	4", 2 Slots	
MAPNET II/IDNet Isolator	2", 1 Slot	
Decoder Module	6", 3 Slots	
System, Remote, or TrueAlert Power Supply	Blocks E, F, G & H ONLY	
Expansion Power Supply	Blocks G & H ONLY	
NAC Expansion Module	On XPS ONLY	
Flex-35 Amplifiers, 2 max /bay*	Blocks E & F; C & D; or A & B	
Flex-50 Amplifiers, 2 max/bay*	Blocks E & F or C & D	
100 W Amplifiers, 1 max/bay	Blocks E, F, G & H	
100 W Backup Amplifiers, 1 max. per bay with primary amplifier	Blocks A, B, C & D	
Telephone Expansion Module	1 Block	
Expansion Signal Module	1 Block	

\* **NOTE:** When mounting dual Flex amplifiers on an expansion bay, special mounting rules apply.

# Enclosure Installation Reference

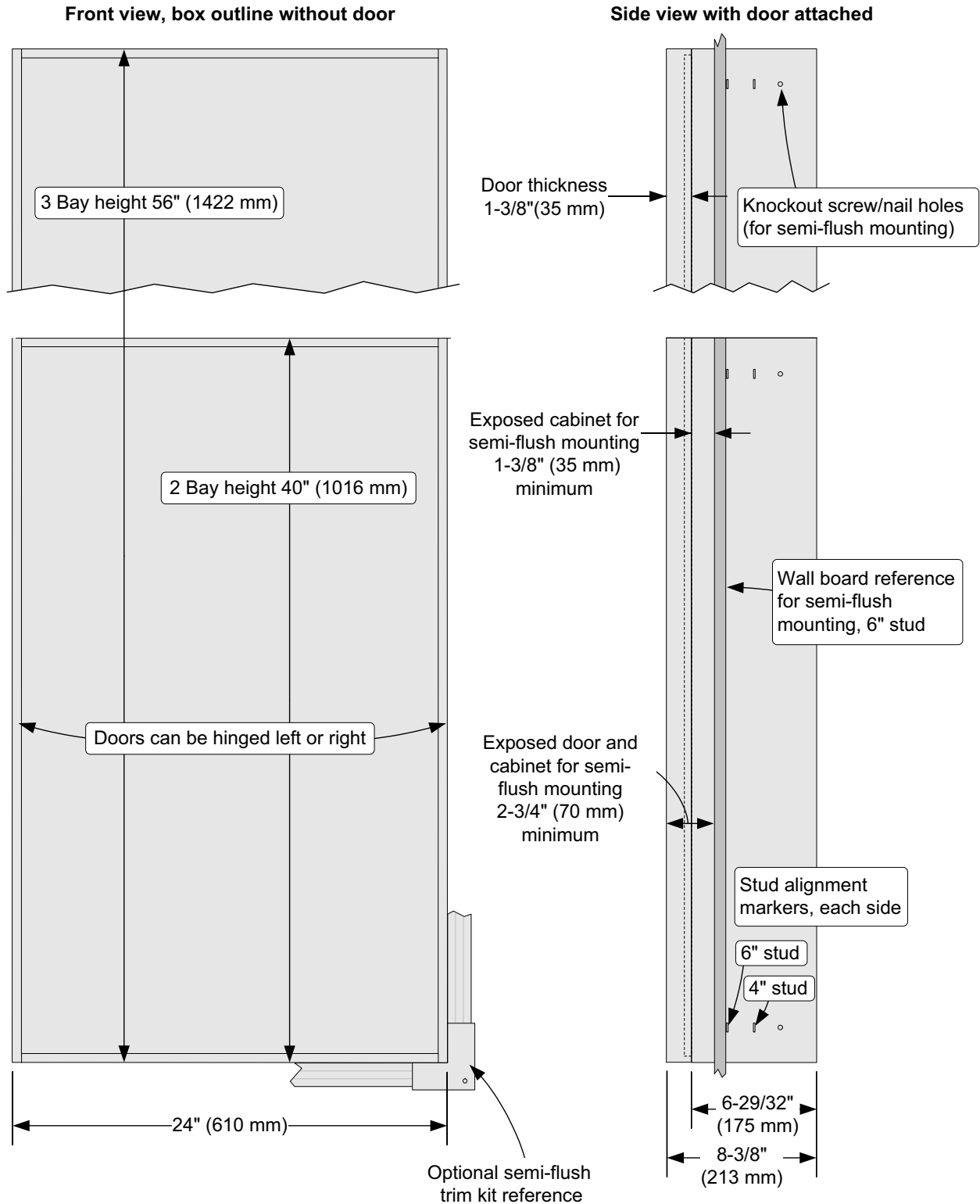

**NOTE:** A system ground must be provided for Earth Detection and transient protection devices. This connection shall be made to an approved, dedicated Earth connection per NFPA 70, Article 250, and NFPA 780.

*Tyco, Simplex, the Simplex logo, MAPNET II, IDNet, TrueAlarm, SmartSync, MINIPLEX, and TrueAlert are trademarks of Tyco International Services AG or its affiliates in the U.S. and/or other countries. VESDA is a trademark of Vision Products Pty Ltd.*